



**Operating
Instructions
Test Set
Multi-Range
No. 1**





CONTENTS

Table of Ranges	4
General Description	4
Limits of Accuracy	5
Design and Construction	6
Range Controls	6
The Movement	7
Scaling	7
Replacement of Internal Battery, Cell and Fuse	7
Replacements	7
Movement Reverse Control	8
Overload Protection	8
Operation of Instrument	9
Current Measurement	9
Voltage Measurement	10
Resistance Measurement	11
Accessories	
D.C. Voltage Multiplier	12
D.C. Shunts	12
Transformers	13
Plug-in Type Leads	14
Servicing	14
Circuit Diagram of the Test Set, Multi-Range No. 1	15

OPERATING INSTRUCTIONS

TABLE OF RANGES

D.C. Voltage	D.C. Current	A.C. Voltage	A.C. Current
3,000 V.	10 A.	3,000 V.	10 A.
1,000 V.	1 A.	1,000 V.	5 A.
300 V.	100 mA.	300 V.	1 A.
100 V.	10 mA.	100 V.	100 mA.
30 V.	1 mA.	30 V.	
10 V.	300 μ A.	10 V.	
3 V.	50 μ A.	3 V.	

Resistance

0–20 megohms, (200,000 ohms mid-scale)

0–200,000 ohms (2,000 ohms mid-scale)

0–2,000 ohms (20 ohms mid-scale)

A range of accessories is available to extend the normal ranges of measurement. These include d.c. voltage multipliers (up to 30kV) d.c. current shunts (125mV drop), and a transformer.

GENERAL DESCRIPTION

This instrument has been specially designed to withstand the rigours of unfavourable climatic conditions, certain components having been 'potted' in an epoxy casting resin which renders them completely impervious to the ingress of moisture and also fungus resisting.

The instrument panel, case, and certain internal components have been produced from a special material which reduces electrical leakage through and across mouldings to a negligible minimum and also renders the meter resistant to fungus growth.

The meter is extremely simple to use, range selection in general being accomplished by means of two switch knobs.

A clearly marked 5" (127 mm) scale has uniformly divided graduations to match 100 and 30 scale markings, and in addition there are separate scale markings for resistance measurement. An anti-parallax mirror permits readings of the knife edge pointer to be made with great precision.

All tests, except those on the 3,000V. ranges, make use of the pair of terminals at the base of the instrument.

OPERATING INSTRUCTIONS

LIMITS OF ACCURACY

Generally speaking, the highest percentage accuracy on current and voltage ranges is obtainable at the upper end of the scale, but on resistance ranges it is better towards the centre of the scale. In the case of voltage measurements, which are more frequently taken than those of current, successive ranges have been closely chosen to obviate the need for taking readings on very small deflections.

The instrument will produce its highest accuracy when used face upwards in which position it has been calibrated.

The Multimeter No. 1 meets the requirements laid down in Defence specification DEF-155. Limits are given as follows:

d.c. voltage and current ranges:— $\pm 1\%$ of full scale value over the effective range.

$\pm 2\%$ 3000V range only.

a.c. voltage and current ranges:— $\pm 2.25\%$ of full-scale value over the effective range.

Variation due to frequency between 50 Hz and 3 kHz is less than a total of 3% of indication on current ranges and voltage ranges up to 300V.

The "effective range" in accordance with British Standards Specification 89/1954, is as follows:

d.c. from 0.1 of full-scale to full-scale value.

a.c. from 0.25 of full-scale to full-scale value.

Resistance. On resistance ranges the instrument will measure to within $\pm 4\%$ of value at mid-scale, increasing to $\pm 10\%$ of indications corresponding to 10% and 90% of full-scale deflection.

Inasmuch as rectifier moving coil instruments give readings on "a.c." proportional to the mean and not the r.m.s. value of the wave form with which they are presented, they depend for their accuracy not only upon their initial calibration, but also upon the maintenance of a sinusoidal wave form. Since the form factor (r.m.s. value divided by mean value) of a sine wave is 1.11, this has been taken into account in calibrating the meter which does, therefore, indicate r.m.s. values on the assumption that the normal sine wave will be encountered. Generally speaking, considerable wave form distortion can occur without appreciably affecting the form factor and resulting accuracy of measurement, but the user should recognise the possibility of some error when using distorted wave forms, squarish wave shapes producing high readings, and peaky ones, low readings.

OPERATING INSTRUCTIONS

DESIGN AND CONSTRUCTION

The instrument consists of a moulded panel on the inside of which are mounted the whole of the switching apparatus, resistances, shunts, transformer, diodes, etc., together with the movement. The panel fits into a robust moulded case, the joint being rendered completely dust proof, whilst a carrying strap is provided to facilitate portability. To provide magnetic shielding, a steel case surrounds the moulded case, this steel casing also increases the mechanical robustness of the instrument. The main switching is accomplished automatically by means of two knobs which indicate on the engraved panel, the range in use. These switches are of generous and robust design, the contacts being arranged to "make" before "break" on adjacent ranges; a feature which provides a factor of safety in use. When the instrument is set for operation on d.c., the moving coil is associated with a universal shunt and series multipliers, whilst on a.c., a full-wave rectifier and transformer are introduced.

RANGE CONTROLS

The left-hand knob provides all the d.c. current and voltage ranges (except 3,000V), and the right-hand knob the a.c. ranges (except 3,000V) and also the resistance ranges. These knobs are electrically interlocked so that d.c. readings can only be made after the right-hand switch has been set to d.c., and the left-hand switch to the range

selected. A.C. readings call for the left-hand switch to be set for a.c. (it must not be left at RESISTANCE) and the right-hand switch at the range required. Resistance tests require the left-hand switch to be set to RESISTANCE and the right-hand one to the desired range.

If the switches are inadvertently left to actual ranges simultaneously, there is no circuit through the meter, and it is thereby safeguarded against accidental damage or misleading readings.

It is possible to determine whether a source is a.c. or d.c., since a.c. will not produce a pointer indication when the meter is set for d.c. measurement. A small pointer indication, however, may result if d.c. current is passed through an a.c. range, but no harm can be done to the meter provided that it is not at the same time grossly overloaded.

The main ranges are engraved on the panel around the switches, and arrow heads on the knobs indicate the actual range selected. In the case of voltage, successive ranges are built up on the ratios of 3.3:1 and 3:1, but in the case of current, a wide coverage has been chosen instead and the 10:1 ratio in general is followed. The 3,000V a.c. and d.c. ranges are available by means of the two special terminals so marked.

Extremely wide coverage in resistance has been achieved by having a fundamental range as marked on the scale, together with ranges of $\times 100$ and $\div 100$ to supplement

OPERATING INSTRUCTIONS

it. Before carrying out resistance tests, the meter should be adjusted for the state of the batteries. It is merely necessary to join the leads together and adjust to zero in the following sequence: Ohms $\times 1$; Ohms $\div 100$, followed by Ohms $\times 100$, using in each case the adjuster to match the range. It is not necessary to re-adjust each time a different range is used, and in fact re-checking for battery condition is only required occasionally.

THE MOVEMENT

The moving coil consists of an aluminium alloy former wound with copper wire and supplemented with Constan-tan in order to reduce temperature error. It is pivoted on hardened and highly polished steel pivots between conical spring-loaded jewels, and swings in a gap energised by two powerfully magnetised and aged 'Alcomax' blocks associated with mild steel pole pieces. Two phosphor bronze hair springs are fitted for the purpose of conveying current to the moving coil, and to provide controlling torque. A knife edge type of pointer is fitted enabling very fine readings to be taken, whilst the whole movement is perfectly balanced and reasonably damped so that the pointer quickly comes to rest. Temperature compensation for the movement is also provided by a thermistor.

SCALING

The scale-plate has three main sets of markings, each of approximately 5" length, the two outermost being for

voltage and current (both a.c. and d.c.) which are marked 0-100 and 0-30 with divisions approximately $1\frac{1}{4}$ mm. apart. The third scale is used for measuring resistance and is calibrated 0-200k ohms (2k ohms mid-scale).

REPLACEMENT OF INTERNAL BATTERY, CELL AND FUSE

Inside the cover, under the carrying strap is mounted a 15V battery and a $1\frac{1}{2}$ V cell together with a 1A fuse and spare fuse. These batteries should be examined from time to time to ensure that the electrolyte is not leaking and damaging the instrument. This condition will generally occur only when the cells are nearly exhausted. If it is known that the meter is going to stand unused for several months, it is preferable that these batteries should be removed to prevent possible damage.

When replacing batteries, the $1\frac{1}{2}$ V cell and the 15V battery must be inserted with the poles to match the markings of polarity inside the battery box. The 1A fuse is located in the battery compartment and is connected in series with the 1.5V cell.

REPLACEMENTS

1.5V cell $1\frac{3}{8}$ " dia. $\times 2\frac{3}{8}$ ", such as Ever Ready U2 (Joint Service Cat. No. Y3/6135/99/910/1101).
15V battery, $1\frac{1}{32}$ " $\times \frac{5}{8}$ " $\times 1\frac{1}{2}$ ", such as Ever Ready B 121 (Joint Service Cat. No. Y3/6135/99/910/1168).

OPERATING INSTRUCTIONS

MOVEMENT REVERSE CONTROL

It sometimes happens that d.c. voltages may be required both positive and negative to a reference point, or the direction of flow may be reversed. In order to simplify the matter of lead alteration, a movement reverse press button (REV.M.C.) is provided. It should be noted that the polarity marked on the terminals is for normal use and does not apply when the button is pressed.

OVERLOAD PROTECTION

One of the most attractive features of the instrument is the provision of an automatic cut-out which gives a very high degree of overload protection to the whole of the instrument. The incorporation of this device will be found to be of particular value when conducting experimental work, for it imparts to the user the feeling of mental ease and confidence. When conducting experimental work with conventional moving coil meters, these can be easily ruined by inadvertently applied overloads, whereas the Avometer is so well protected that it can withstand considerable mishandling.

If an overload is applied to the meter, the cut-out knob springs from its normal position in the panel, thus breaking the main circuit, and this knob has only to be depressed to render the instrument again ready for use. It is important to note that the cut-out should never be reset when the instrument is connected to an external circuit, whilst the

fault which caused the overload should be rectified before the meter is reconnected.

The mechanism is brought into operation by the moving coil coming into contact with a trigger just beyond its full-scale position. There is, in addition, a second release at the zero end, so that the cut-out is tripped if the meter is overloaded in reverse.

Additional protection is provided on the ohms and ohms \div 100 ranges by means of a 1A fuse located in the battery box.

Although the overload mechanism gives almost complete protection to the meter, it cannot be guaranteed to fulfil completely its function in the very worst cases of misuse, such as the mains being connected across the meter when set to a current range. It should be noted that mechanical shock to instrument will sometimes trip the cut-out mechanism. The cut-out should be reset, using direct pressure and without twisting the button, and with the instrument lying face upwards.

WARNING

*Special care must be taken when using the instrument to service television receivers or other apparatus employing capacitors of large capacity, for the inclusion of such components in a circuit may mean that **very high peak***

OPERATING INSTRUCTIONS

currents may flow when the apparatus is switched on. Such surges produce a peaky wave form, and although these peaks are only a few milli-seconds duration, they may, never-the-less, puncture the instrument rectifier.

OPERATION OF INSTRUMENT

The instrument is intended for use horizontally. Should it happen by any chance that the pointer is not on zero, it may be so set by means of the screw head on the panel. The meter is supplied complete with a pair of rubber covered leads, the ends of which plug into the terminals. The remote ends are fitted with spring clips which may be interchanged with the prods supplied with the instrument.

When measuring current or voltage, ensure that the instrument is set to match the type of source to be measured (either a.c. or d.c.) and then choose a suitable range before connecting up to the circuit under test. When in doubt always switch to the highest range and work down. Do not,

however, switch off by rotating either of the knobs to a blank position.

The instrument is flash-tested at 5,000V a.c., but should the meter be used with accessories on circuits in excess of 3,000V, it should be kept at the low potential end of the circuit (near the earth potential). If this procedure cannot be adopted other suitable safeguards must be employed.

CURRENT MEASUREMENT

To measure current, the instrument should be set to a suitable a.c. or d.c. range, and then connected in series with the apparatus to be tested.

Generally speaking, the power absorbed in the instrument is negligible, but in cases of low voltage heavy current circuits, the inclusion of a meter may reduce the current appreciably below the value which would otherwise prevail. The potential drop at f.s.d. across the meter terminals does not exceed 750mV on all d.c. ranges, except the 50 micro-amp range which has a drop of 125 milli-volts. In the case of a.c., it is less than 200 milli-volts on all ranges.

Standard meter leads have a resistance of 0.02 ohms per pair.

In certain cases, care should be taken to ensure that the circuit is "dead" before breaking into it to make current measurements.

OPERATING INSTRUCTIONS

VOLTAGE MEASUREMENT

When measuring voltage, it is necessary to set the appropriate range of "a.c." or "d.c." and connect the leads across the source of voltage to be measured. If the expected magnitude of the voltage is within the range of the meter, but its actual value is unknown, set the instrument to its highest range, connect up and if below 1,000V rotate the appropriate selector switch, decreasing the ranges step by step, until the most suitable range has been selected. If the voltage should exceed 1,000V the instrument should be set to measure 1,000V as already described, but the negative load should be transferred to the appropriate 3kV terminal. Great care must be exercised when making connections to a live circuit, and the procedure should be entirely avoided if possible.

On d.c. ranges, the meter consumes only 50 microamps at full scale deflection, this sensitivity corresponding to 20,000 ohms per volt. In the case of a.c. ranges from 100V upwards, full scale deflection is obtained with a consumption of 1mA. (1,000 ohms per volt). The 30V., 10V., and 3V. a.c. ranges consume 3, 10 and 30mA respectively at full scale deflection. The change of indication from that at 50Hz on all current ranges and voltage ranges up to and including 300V does not exceed 3% of the indication up to 3kHz but the meter maintains a high degree of accuracy for audio frequency tests up to 10kHz on ranges up to 300V a.c.

Whilst discussing the problem of measuring voltage, it would be well to draw attention to the fact that in certain circuits where the current is limited because of the presence of a resistance between the source and the point at which a measurement is to be made, it is possible for the actual voltage to be higher normally than when the meter is connected. All current consuming voltmeters, however sensitive, draw current to varying degrees from the circuit under test, this causing a higher volts drop in the resistances mentioned, and thereby causing the voltage to fall at the point of measurement.

Owing to the high sensitivity of the Multimeter No. 1 on its d.c. ranges, this effect is unlikely to be of importance except in a very few instances. A practical example of where it might be taken into account is in the measurement of the voltage on a television set or the tapping on a potential divider, where the resistances are so high as to be comparable with the resistance of the meter on the range in use. It is generally possible to use a meter on a higher range than absolutely necessary, and in such a case the higher meter resistance causes less disturbance than would otherwise be the case. At the same time adequate pointer deflection for reasonable accuracy should be attained.

When it is essential to obtain an accurate indication of the voltage developed across a high resistance it is sometimes preferable to insert the meter in series with it, and to measure the current flowing. The reading given upon the

OPERATING INSTRUCTIONS

meter, in milliamps, multiplied by the value of the resistance in thousands of ohms, will give the developed voltage.

RESISTANCE MEASUREMENT

There are three self-contained ranges which cover measurements from 0.5 ohms to 20 megohms, these make use of the usual series circuit, successive ranges are on 100 : 1 ratio, which permits very wide coverage using three ranges.

On resistance ranges, the meter must not merely start from its normal instrument zero, but must have, in addition, a resistance zero corresponding to the full scale deflection of the meter. Before carrying out tests for resistance a check, and if necessary adjustment, should be carried out to ensure that when the leads are joined together the meter actually indicates zero ohms, irrespective of the condition of the battery (within the limits of adjustment). The method of adjustment is described below.

Resistance tests should never be carried out on components which are already carrying current, or contain a source of voltage.

When using the instrument it should be remembered that a positive potential appears at the negative terminal of the instrument when set for resistance tests. This fact may be important because the resistance of some components varies according to the direction of the current through them and readings, therefore, depend upon the direction in which

the test voltage is applied, quite apart from its magnitude. Such cases include electrolytic capacitors and rectifiers.

When measuring the leakage resistance of an electrolytic capacitor, the negative lead from the meter should be connected to the positive terminal of the capacitor, and the ohms $\times 100$ range employed.

Before making resistance tests the pointer should be adjusted to zero in the following sequence :—

1. Set left-hand switch at 'RESISTANCE'.
2. Join leads together.
3. On the Ω range, adjust to zero by means of the knob marked "ZERO Ω ".
4. On the " $\Omega \div 100$ " range, adjust to zero by means of the knob marked "ZERO $\Omega \div 100$ ".
5. On the " $\Omega \times 100$ " range, adjust to zero by means of the knob marked "ZERO $\Omega \times 100$ ".

To test a resistance, set the right-hand switch at the range required, the leads being connected across the unknown component.

Resistance is read directly on the " Ω " range, but indications should be divided or multiplied by 100 on the other two ranges.

If on joining the leads together it is impossible to obtain zero ohms setting, or if furthermore the pointer position will not remain constant, but falls steadily, the internal battery

OPERATING INSTRUCTIONS

ACCESSORIES

or cell concerned should be replaced. It is important that a discharged unit should not be left in the instrument, since the electrolyte might seep through and cause damage to the meter.

Notes

(a) It can so happen that a 15-volt battery may age in such a manner that although it indicates a potential of 15 volts, its internal resistance has increased so much that some loss of accuracy can occur on the high resistance range ($\Omega \times 100$). If the battery has been in use for some time, or if errors are suspected on the high resistance range, it is worth while removing the battery and checking its short circuit current on the 100mA. d.c. range. If the battery fails to give a reading greater than 5mA, it should be discarded.

(b) If it is impossible to obtain readings on the ohms or the ohms \div 100 ranges the 1A fuse located in the battery box should be checked.

D.C. VOLTAGE MULTIPLIERS

General Note : When measuring high a.c. and d.c. voltages (say above 800V.) unless the common positive terminal is either earthy or connected to earth, errors will be introduced if the instrument is touched during a reading.

Combined 10kV. and 30kV. d.c. Voltage Multiplier

A combined 10kV and 30kV d.c. multiplier is available for use with instrument. The multiplier should be connected to the Avometer set to the 10V d.c. range. It is recommended that the meter is kept as near earth potential as possible and the multiplier used at the high potential end, e.g. when measuring an e.h.t. voltage where the negative line is earthy, the multiplier should be connected between the point of positive potential and the positive terminal of the meter. A cap is provided with the multiplier which should always be in position over the high voltage terminal not in use.

It is recommended that neither the meter, multiplier or leads are handled whilst high voltage tests are in progress. Protection is provided by a resistor connected permanently across the multiplier terminals thus preventing the full voltage being present should the meter be disconnected.

D.C. SHUNTS

Shunts are available to extend the d.c. current ranges. The shunt should be connected by means of its two main terminals in series with the circuit to be measured. The

ACCESSORIES

meter, set to its $50\mu\text{A}$ (125mV) d.c. position should then be connected to the two small studs on the shunt end blocks.

The Avometer when so set, consumes only $50\mu\text{A}$ at full-scale deflection, a value which is negligible in comparison with the full-scale current of the shunt. The millivolt drop across the shunt is directly proportional to any current which may flow through it and since the deflection on the meter is directly proportional to the millivolt drop across its terminals, the instrument indicates correctly over its entire scale length.

Shunts for 30A, 100A, 300A and 600A are available.

TRANSFORMERS

Transformers are available to extend the a.c. current ranges, when set to 100mA a.c. It is necessary to connect the meter set to its 100mA range to the secondary of the transformer before current is passed through the primary, and care should be taken that the cut-out is in position. If this course is not followed, quite a considerable voltage will appear at the secondary terminals, if current passes through the primary. Transformers for 30A, 100A and 300A. (No longer supplied.)

SERVICING

MULTI-RANGE CURRENT TRANSFORMER

This transformer replaces the range of transformers described in the above paragraph. It may be used on any a.c. current range up to 1.5A to provide a comprehensive range of full scale values up to 600A a.c. (See Operating Instructions packed with each transformer.)

ACCESSORIES

SERVICING

PLUG-IN TYPE LEADS

When ordering replacements, the following description and part numbers should be quoted :

	Part No.
Connector No. 2 (Black)	20913F*
Connector No. 2 (Red)	20913E*
Clip	12381B
Long Reach Safety Clip Mk. 2 (Black)	21443A
Long Reach Safety Clip Mk. 2 (Red)	21443B

*If these Part Numbers are not quoted, the older type of leads (with hook terminations) will automatically be supplied.

Due to the high operational standards maintained throughout our organisation, and the close limits within which we work, breakdowns are comparatively rare, and can often be traced to transit damage or careless handling, for which the Company cannot be held responsible. If, however, your instrument should require servicing or a calibration check, we at Avo have the knowledge and equipment to repair your instrument to the highest possible standard.

For those customers who feel they have the necessary skill and equipment to carry out their own servicing requirements, spares are available from Avo Limited. To obtain the correct spares item, identify the component required and state its position in the instrument. Where applicable state the circuit reference number. Should you at any time have to return your instrument to the Company for repair, pack it carefully and enclose a note informing our engineers of the faults which you have found. Customers outside the U.K. should contact the Avo representative for their territory.

CIRCUIT DIAGRAM

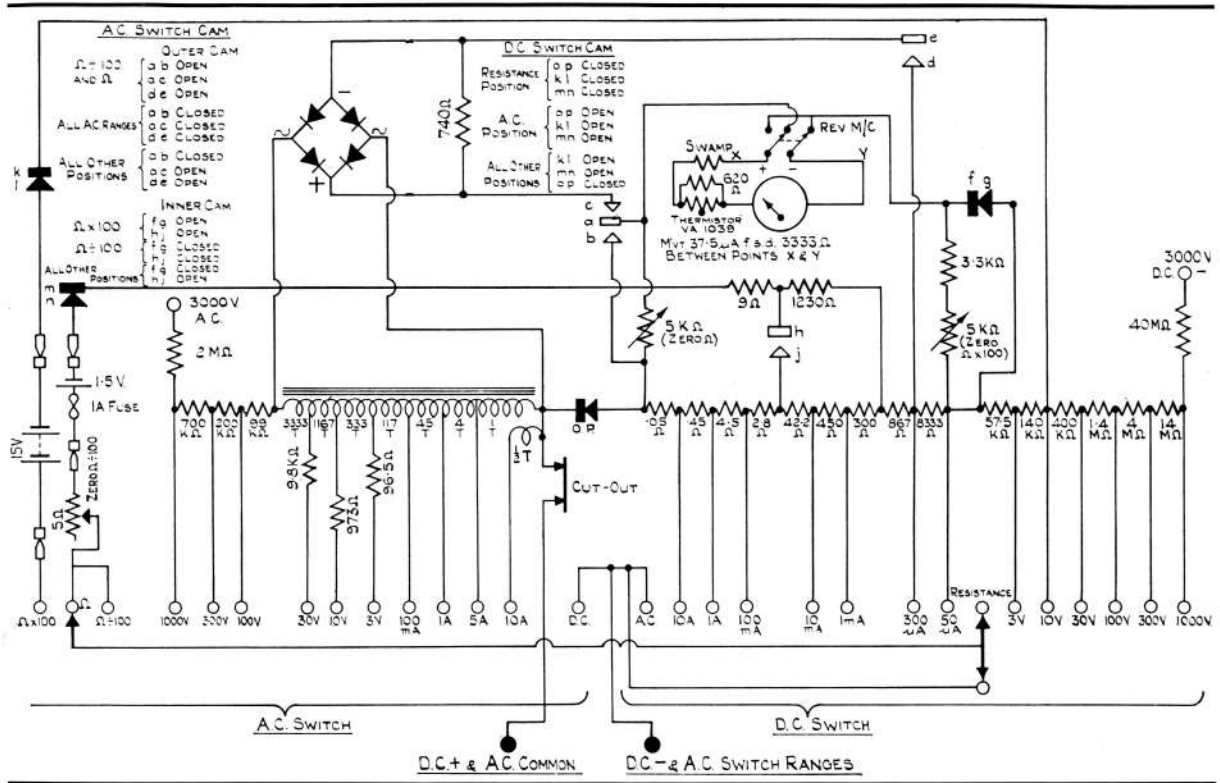



Avo Limited

Avocet House
Dover, Kent, England
Tel : Dover 2626

Telegrams & Cables :
Avocet Dover
Telex : 96283



Part No. 93014

Printed in England