



Service Manual

BM7 Battery MEGGER Testers



Contents

Chapter	Page No
– London Instrument Repair Centre	4
1. Introduction	5
2. Repair requirements	6
3. Fault location	7
4. Fault diagnosis and repair	10
5. Preliminary re-assembly	13
6. Re-calibration	14
7. Final re-assembly	15
8. Circuits and Components	16
<i>Figure 1</i> The battery compartment, with access to fuse	7
<i>Figure 2</i> BM7 Front Cover assembly including Range Switch S2	9
<i>Figure 3</i> BM7-250 Functional circuit with range switch S2 (omitted for clarity) in the 'MΩ' position	17
<i>Figure 4</i> BM7-500 functional circuit with range switch S2 (omitted for clarity) in the 'MΩ' position	17
<i>Figure 5</i> Functional circuit with range switch S2 (omitted for clarity) in the 'Ω' position	18
<i>Figure 6</i> Functional circuit with range switch S2 (omitted for clarity) in the 'B' position	18
<i>Figure 7</i> BM7-250 Component Location	21
<i>Figure 8</i> BM7-250 Circuit Diagram	22
<i>Figure 9</i> BM7-500 Component Location	24
<i>Figure 10</i> BM7-500 Circuit Diagram	25



Service Manual

BM7

Battery MEGGER Testers

Model number	Catalogue number	Testing voltage
BM7-250	40051	250V
BM7-500	40050	500V

INSTRUMENT REPAIRS and SPARES

Manufacturer's joint service and spares organisation for MEGGER Testers

LONDON INSTRUMENT REPAIR CENTRE

Spares & Repairs

Archcliffe Road,
Dover,
Kent. CT17 9EN.
England.
Tel: Dover (0304) 202620
Telex: 96283 LIRC

Repairs Only

Cunnington Street,
Acton Lane Works,
Chiswick,
London, W4 5HJ.
Tel: 01-995 9212
Telex: 22583 LIRC

Instruments may be delivered to either address. Trade Reception counters are provided. Spare parts and Service Manuals should be ordered from the Dover Unit.

Individual Calibration

MEGGER Testers incorporating cross-coil movements are individually calibrated. Repairs to these instruments should not be attempted unless facilities for re-calibration are available.

Overseas

Instrument owners outside Great Britain should consult the Appointed MEGGER Distributor for their country regarding spares and repair facilities. The Distributor will advise on the best course of action to take.

If returning an instrument to Britain for repair, it should be sent, freight pre-paid, to L.I.R.C. AT DOVER (not to the Chiswick Unit). A copy of the Invoice and of the Packing Note should be sent simultaneously by airmail to L.I.R.C. at Dover to expedite clearance through the U.K. Customs.

A repair estimate showing return freight and other charges will be submitted to the sender before work on the instrument commences.

MEGGER TESTERS ARE GUARANTEED FOR 12 MONTHS
FROM THE DATE OF PURCHASE BY THE USER.

1.0 Introduction

The Instrument

This instrument is designed to be suitable for use by electrical installation contractors and as such is a robust meter having a stabilized power supply, thus requiring no zero adjustment, etc. after initial calibration by the Manufacturer. However, it is inevitable that normal wear and tear will eventually cause the performance of the instrument to deteriorate.

1.2 The Manual

This manual covers both BM7 models. Their comparative specifications are given for identification purposes.

This manual has been produced as an aid to the trained Technician who undertakes the servicing of these instruments. The design of the instrument is such that a minimum of equipment is required and components are easily accessible.

If the customer has not advised that the repair may be undertaken irrespective of your charges, we strongly recommend that the instrument should be examined and an estimate submitted before any work is undertaken. This procedure, and the acceptance of the estimate, will provide a safeguard against disputes arising over a charge for the work after the necessary repairs have been completed.

1.3 Specification

BM7 Battery *MEGGER* testers use an electronically generated test voltage, which is energised only while TEST button is pressed. One hand operation. Automatic discharge of circuit capacitance. On-load battery check. Taut-band, moving coil movement.

	BM7-250	BM7-500
	Cat No. 40051	Cat No. 40050
MEGOHM RANGE	0-50M Ω at 250V	0-100M Ω at 500V
CONTINUITY RANGE	0-100 Ω at 300mV	0-100 Ω at 300mV
BATTERIES	6 \times HP7 cells (1.5V each) or equivalent	
FUSE	750mA fuse on both ranges. International size 20 \times 5mm	
DIMENSIONS	153 \times 59 \times 95mm (6 \times 2 $\frac{5}{8}$ \times 3 $\frac{3}{8}$ in)	
WEIGHT	0.57kg (1lb 4oz) instrument and batteries	

1.4 Accessories

The instrument is supplied complete with testing leads and batteries
Optional extras.

Cat No. 40090 leather carrying case

Cat No. 40091 Imitation leather case

Cat No. 63355 A 3-compartment combination case

2.0 Repair Requirements

2.1 Introduction

The following lists the working conditions and the test equipment required for making meter repairs.

2.2 Working conditions

The room in which the repairs are to be carried out should preferably be air conditioned and well lit by diffuse light. The work top should be surfaced with some smooth, light coloured material, eg formica, linoleum, etc.

Do not smoke since inflammable vapours from cleaning fluids may be present. Be careful to avoid excessive lighting as this will cause glare and operator discomfort.

2.3 Tools and other aids

Desoldering equipment with solder removal facilities.

A small soldering iron.

Tweezers suitable for light work.

Pliers (various sizes).

Side cutters.

An eye glass.

A blower brush.

Various screw drivers.

A screw driver with a very fine $\frac{1}{16}$ in blade for adjusting potentiometers.

BA box spanners (4BA, 8BA).

(a) *Instruments and test gear*

Ammeter (minimum range 0–500 μ A). An *AVOMETER* Model 8 or Model 9 is suitable.

Ohmmeter, eg *AVOMETER* Model 8 (for fault finding).

Resistors—100 Ω , 0.1M Ω , 1M Ω , 10M Ω (all $\pm 1\%$ tolerance).

Set of instrument leads.

Draught-proof box with mountings for movement and connections for test purposes.

(b) *Spare parts*

To help with the above the following is recommended to be maintained:

A stock of spare parts (see Recommended spares list, page 19).

6 recently manufactured cells (type HP7 or equivalent).

2.4 Miscellaneous items

Some small containers to hold piece parts.

Small glass jars with lids for fluids (eg alcohol for switch cleaning and liquid soap for cleaning the case and glass).

A reel of good quality cored solder (60% tin, 40% lead) in 20 swg.

Lint free cleaning cloth.

Vaseline.

MS4 silicone grease (Midland Silicone).

Red locking varnish (Sterling B8).

White Bostik adhesive for glass fixing.

3.3 Initial test

First check the leads, prods and clips for continuity as these will affect the performance of the instrument and replace as necessary. Check operation of meter.

3.4 Dismantling

- (a) If the instrument still fails to function properly it will be necessary to examine the internal circuitry. To achieve this, first remove the Cover assembly by turning the instrument on its face and removing the four *small* seals, thus revealing four 6BA screws. (Do *not* remove the two large seals as the nuts below these secure the movement magnet and will remain in place when the movement is removed.) The four brass screws are then undone and the instrument turned face up. The Cover assembly can then be removed by lifting it at the switch end. (Since this assembly contains switch contacts which are necessary for circuit continuity, we recommend, in cases where repeated repairs are envisaged that a substitute cover is obtained, drilled to allow access to the four potentiometers which will require adjustment.) Having removed the Cover assembly, inspect the instrument for obvious faults such as a 'sticky' micro-switch, range switch contacts not contacting with the printed circuit board, dirt in the movement.

(b) *Removal of the printed circuit board*

Once the fault has been diagnosed it may be necessary to remove the printed circuit board so that faulty components may be removed and replaced. The procedure is as follows:

- (i) First remove the Cover assembly from the instrument as explained in paragraph (a) above.
- (ii) Note the point on the printed circuit board where the red and black leads (* in Figs. 7 and 9) to the meter movement are connected, then disconnect at these points.
- (iii) Carefully lift out the printed circuit board and disconnect the remaining leads attached to the underside of the board.

(c) *Removal of meter movement*

If the movement is to be repaired or exchanged it may be removed from the instrument as follows:

Release and keep for re-use the two screws holding the movement to the instrument case.

Carefully lift out the movement and store in a dust-proof box.

3.0 Fault Location

3.1 Visual inspection

On receipt of the instrument to be repaired, it should be examined carefully for signs of visual damage caused before or while the instrument was in transit (assuming the instrument has not been brought by hand).

Always provide the customer with full details of any suspected transit damage as he may wish to claim financial damages from the carrier responsible for shipping the instrument, and because of this you should retain the packing material in which the instrument arrived. It is also important that the carriers be informed of the damage without delay.

Make an inventory of exactly what the customer has sent you (ie case, leads, batteries etc.) and label *all* components so that they can be identified later. Ascertain why the instrument was sent to you, ie what fault is present.

N.B. The movement is a $175\Omega \pm 15\%$, $250\mu\text{A}$ FSD microammeter with taut band suspension. We do not recommend that any attempt should be made to repair a faulty movement which should be returned to London Instrument Repair Centre, Dover, Kent, England for replacement.

3.2 Electrical inspection

Fit new cells. (These are located under a plate on the back of the instrument.) Check that the polarity of the cells is correct. Check whether the instrument is now functioning properly since, although a battery condition indicator is fitted, many instruments are submitted for repairs which merely require a new set of cells. Check that the correct fuse is fitted and intact, fuse holders clean and tight, instrument terminals clean and tight and check that the screws and nuts on the battery contacts are clean and tight.

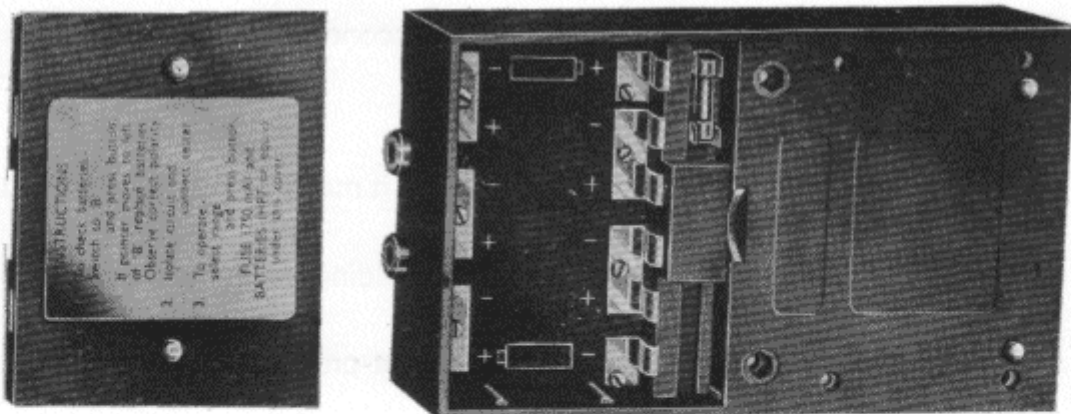

Figure 1
The battery compartment, with access to fuse.

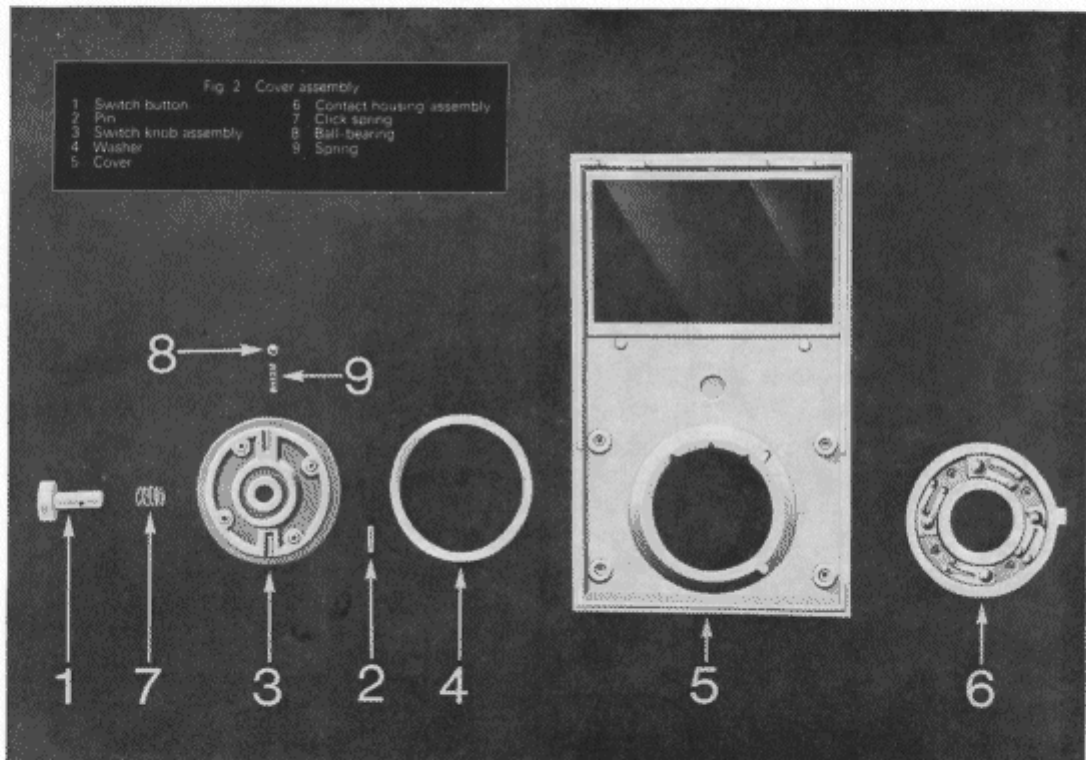

Figure 2
BM7 Front Cover assembly including Range Switch S2

(d) *Dismantling the range switch assembly*

Turn the instrument Cover assembly (see Fig. 2) on to its face thereby revealing the four switch contacts.

Remove the four 8BA screws located between the switch contacts on the contact housing assembly (6).

Gently prise the contact housing assembly (6) away from the cover (5) taking extreme care not to lose the ball bearing and spring (8) and (9).

When the contact housing is removed these items are liable to jump clear.

Store the ball bearing and spring safely and press the switch knob assembly (3) clear of the cover. Remove the washer (4).

Depress the switch button (1) and remove the locking pin (2). Withdraw the switch button (1) and click spring (7).

To re-assemble the range switch carry out the above procedure in reverse order ensuring that the range selector reads ' Ω ' when the locating pin of the contact assembly is touching the switch stop marked 'A'.

4.0 Fault Diagnosis and Repair

If all the above checks have been carried out and the instrument still fails to operate, some fault finding will be necessary. To aid in the correct diagnosis the following is a fault finding table based on possible faults you may encounter. Also refer to appropriate circuit diagrams and printed circuit board (PCB) diagrams, Figs. 7 and 8, 9 and 10.

Fault finding table

<i>Function selected</i>	<i>Symptom</i>	<i>Probable fault</i>
'B'	No deflection	(i) Open circuit switch (ii) Open circuit resistor R3 (iii) Broken track on PCB (iv) Open circuit meter connection (v) Dirty PCB (vi) Switch contacts not touching PCB
	Low deflection	(i) R3 wrong value
	Pointer crashes to extreme right of scale	(i) R3 wrong value (ii) 'Bridging' between tracks
	Low deflection and pointer drifts	(i) C2 reversed
M Ω '	No deflection (also on ' Ω ' range)	(i) 'Bridging' between tracks (ii) Broken track (iii) Dry joint in C1, VT1, D1, R1, RV1 (iv) Open circuit components as in (iii) (v) D1 faulty (vi) Dirty PCB (vii) Switch contacts not touching PCB
	No deflection (but ' Ω ' range correct)	(i) Bridging between tracks (ii) Broken track (iii) Dry joint, eg Transformer R2, R4, R5, R6, R10, R11, R13, R14, D6, D8, TH1 (iv) Open circuit components as in (iii) (v) Wrong value R4, R5 (vi) D2, D3, D4, D5 faulty (also D7, D8 on 250V model) (vii) Dirty PCB

<i>Function Selected</i>	<i>Symptom</i>	<i>Probable fault</i>
	No deflection (but ' Ω ' range crashing)	(i) Transformer flying lead open circuit (ii) D2, D3 open circuit or missing (iii) Fuse open circuit
	Low deflection (also on ' Ω ' range)	(i) Dry joint VT1, D1, RV1 (ii) Low gain or leaky VT1 (iii) D1 faulty
	Low deflection (but ' Ω ' range correct)	(i) Dry joint or open circuit VT2, VT3, R10, C4, Transformer D4, D5 (also C5, C6 & C7 on 500V model) D4, D6 and C5 on 250V model (ii) Low gain or leaky VT2, VT3 (iii) D3, D2, D4, D5 reversed (also D7, D8 on 250V model) (iv) Open circuit transformer primary (v) R10 wrong value (vi) D6, C8 reversed or faulty (vii) Short circuit transformer primary
	High deflection	(i) Transformer reversed (ii) Open circuit D1, D6 (iii) Faulty RV1, RV2, D1 (iv) Dry joints R9, R11, RV2, D6 (v) Wrong value RV4, R9, R11, R13
	Unsteady reading	(i) Dry joint or faulty RV1
	Pointer moves slowly at first then crashes	(i) C1 faulty or reversed
	Low deflection and pointer drifts	(i) C3 open circuit or dry joint (ii) D1 faulty
	Low deflection and pointer vibrates	(i) Leaky D6, VT2, VT3 (ii) VT2 or VT3 bridged
	Pointer drifts visibly	(i) VT1 leaky
	Zero ohms too high	(i) Fuseholder dirty (ii) Loose or wrong fuse

<i>Function Selected</i>	<i>Symptom</i>	<i>Probable fault</i>
Ω	No deflection	(i) 'Bridging' between tracks (ii) Broken track (iii) Dry joint C1, VT1, D1, R1, R8, R12, RV1, RV3 (iv) Open circuit components as in (iii) (v) D1 faulty (vi) Dirty PCB (vii) R14 bridged (viii) Switch contacts not touching PCB
	Low deflection	(i) R8 wrong value
	High deflection or pointer crashes	(i) R14 open circuit or dry joint (ii) Fuse open circuit (iii) Fuse wrong value
	Zero ohms too high	(i) Fuse holder dirty (ii) Loose or wrong value fuse

While these are by no means all the faults which may occur, due to amateur repairs or general ageing, we believe the above table will be useful in tracing most of them. To assist in diagnosing faults which do not appear in this list we include, in this manual, circuit diagrams applicable to individual range settings, as well as comprehensive circuit diagrams for both 250V and 500V instruments.

5.0 Preliminary Re-Assembly

5.1 The meter movement and the printed circuit board may be re-assembled into the instrument case as follows :

(a) *Re-assembly of meter movement*

- (i) Carefully re-position the meter movement in the instrument case.
- (ii) Secure the movement using the two screws retained for this purpose.

(b) *Re-assembly of the printed circuit board*

- (i) Re-connect the leads to the underside of the printed circuit board.
 - (ii) Carefully replace the board in the instrument case.
- (iii) Re-connect the red and black leads joining the movement to the printed circuit board. The red lead connects to the front end of the movement axis.

6.0 Re-Calibration

Having repaired any faults discovered, it will be necessary to carry out a recalibration of the instrument. It is assumed that the movement or board that was removed has now been replaced. If the following procedure is followed no difficulty will be encountered in restoring the instrument to its original condition.

6.1 Setting the output voltage

This adjustment *must* be performed first since it affects several functions. Set the range switch to 'M Ω ' and connect a 1M Ω resistor in series with a 500 μ A ammeter across the instrument terminals. Press the test button and adjust RV1 until the ammeter reads 460 μ A. (On the 250V model adjust to 211 μ A.)

6.2 Adjusting for zero deflection

With the test button released, move the ligament adjuster until the pointer settles over the ∞ mark on the 'M Ω ' scale.

6.3 Setting the 'M Ω ' range

- (i) With the range switch set to 'M Ω ', connect a 1M Ω resistor across the instrument terminals. Press the test button and adjust RV4 until the pointer reads *slightly* to the right of the 1M Ω mark.
- (ii) Release the button and replace the 1M Ω resistor with a set of instrument test leads shorted together. Press the test button and adjust RV2 until the pointer indicates zero.

Repeat (i) and (ii) as necessary.

These two adjustments are inter-dependent but the over adjustment described at stage (i) minimises the number of subsequent operations.

6.4 Setting the ' Ω ' range

Set the range selector to ' Ω '. Attach a new set of instrument leads and connect a 100 ohm resistor between the crocodile clips. Press the test button and adjust RV3 until the pointer reads 100 Ω .

7.0 Final Re-Assembly

7.1 With the repair and re-calibration carried out, the meter may be finally re-assembled as follows :

- (i) Check the position of the printed circuit board for the top cover retaining screws to pass through.
- (ii) Check that there are no leads or foreign matter likely to foul the instrument pointer. Apply a very light smear of Vaseline to the switch track.
- (iii) After cleaning the glass, carefully replace the top cover. Turn the instrument over and replace the four 6BA screws. Check that the switch contacts and the press button operate smoothly. Tighten 6BA screws.

Reseal the screw holes.

8.0 Circuits and Components

8.1 The Electronic Voltage Generator

In Figures 3 and 4 the Transistors VT2 and VT3 form an oscillator circuit generating an a.c. voltage. Transistor VT1 is used as a stabiliser that can be controlled by RV1 to regulate the output of VT1, VT2.

In operation, the output from VT2, VT3 collectors appears across the centre-tapped primary winding of T1. Feedback to the base of VT2, VT3 is provided by another centre-tapped primary winding. This forms the oscillatory circuit.

The oscillator output appears across the secondary of T1 and is applied to a rectifying circuit. On the 250V tester this is a full wave bridge rectifier comprising D4, D5, D6 and D7. On the 500V model a voltage doubler is employed using D4, D5, C5 and C7.

In both models resistance capacity smoothing is used, the negative side of the output being taken to the black terminal of the instruments. The positive side being returned to a common positive rail.

VT1 has zener diode D1 connected in the base circuit. Voltage on the base is tapped off at—RV1. By adjusting RV1 the bias level can be altered and thus the level of output voltage present at the emitter.

8.2 The 'Megohms' function

The converter and stabiliser provide a dc output from the internal dry battery. Reference to Fig. 3 BM7–250 and to Fig. 4 BM7–500 shows that the negative output from the converter passes via R10 to the black terminal on the meter. The circuit is completed via the insulation under test to the positive meter terminal. From this point, current flow is via the megohm range adjuster RV4, series resistor R13, through the meter M1 and back to the power supply.

The network across M1 comprises a diode in series with three resistors, the whole being by-passed by a capacitor. The function of this network is to correct the action of the meter at particular positions on the scale, giving a more uniform response. In effect, scale shaping. The thermistor is included to compensate for minor temperature variations.

The resistor R15 discharges any voltage left in a capacitive circuit, when the push button is released after testing and switch contact S1 B is operated.

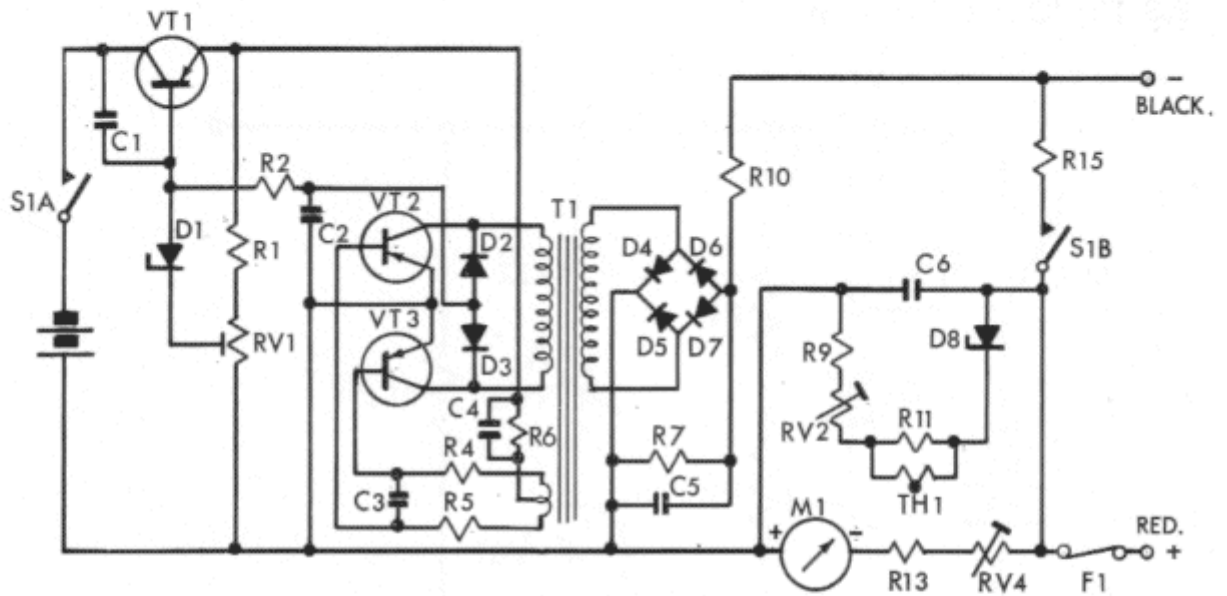

Figure 3
 BM7-250 functional circuit with range switch S2 (omitted for clarity)
 in the 'MΩ' position

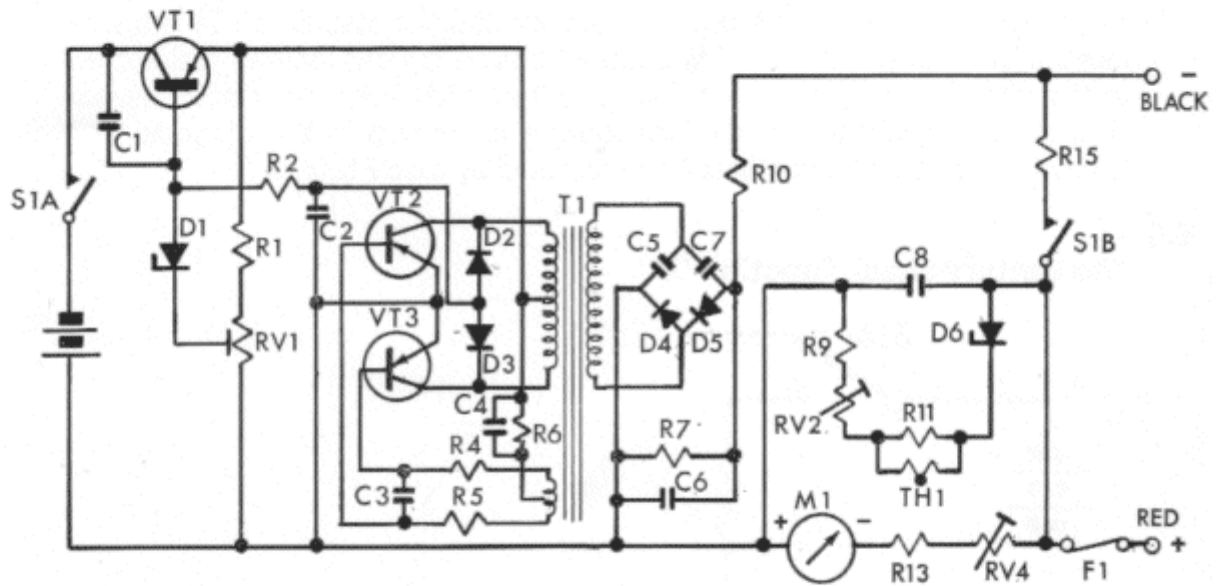

Figure 4
 BM7-500 functional circuit with range switch S2 (omitted for clarity)
 in the 'MΩ' position

8.3 The 'Ohms' function

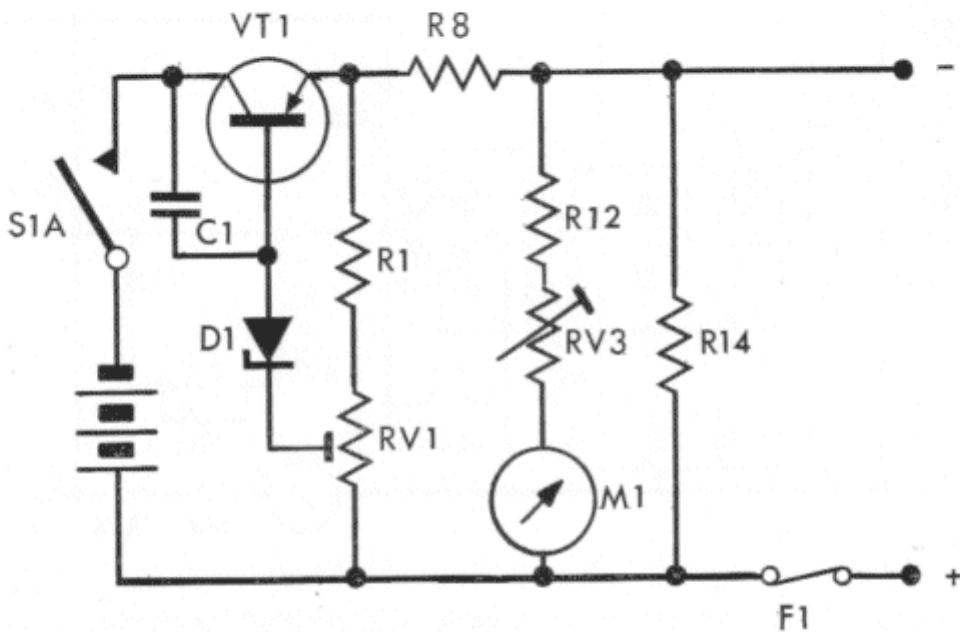

Figure 5
Functional circuit with range switch S2 (omitted for clarity) in the ' Ω ' position

Reference to Fig. 5 shows how the battery and the stabiliser VT1 are employed. The output from VT1 is passed through current limiting resistor R8 to the negative instrument terminal. The meter M1 with adjustable resistor RV3 is placed across the stabiliser output as shown in the diagram. The 'Ohms' position on the meter is also protected by fuse F1.

8.4 The Battery check function 'B'

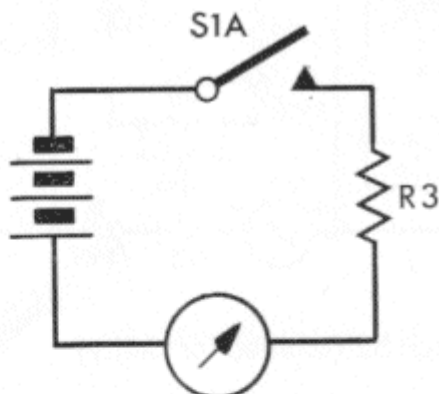

Figure 6
Functional circuit with range switch S2 (omitted for clarity) in the 'B' position

Reference to Fig. 6 shows that with 'Battery Check' selected, the meter movement M1 and resistor R3 are connected in series across the battery when push-button S1 A is operated. M1 then gives a reading of the battery condition. No other part of the meter is in circuit when switch position B is used.

Recommended spares

Instrument Repairers are recommended to stock these spare parts for the repair of MEGGER BM7 testers.

<i>Item no.</i>	<i>Description</i>	<i>Part no.</i>
1	Test lead (red)	6320-058
	Test lead (black)	6320-059
2	Instruction card	6170-418
3	Fuse	25413-252
4	Cover assembly (complete)	6330-414
5	Window	5140-021
6	Case assembly (complete)	6330-412
7	Battery cover	5110-024
8	Terminal socket (black)	25267-207
9	Terminal socket (red)	25267-208
10	Battery clip (large)	5130-044
11	Battery clip (small)	5130-045
12	Movement (complete) BM7-500	6330-415
	Movement (complete) BM7-250	6330-416
13	Printed circuit board assembly (BM7-500)	6230-314
	Printed circuit board assembly (BM7-250)	6230-315
14	Transformer	A27888-770
15	Microswitch	25475-556
16	Potentiometer RV1	27284-762
17	Potentiometer RV2	27284-763
18	Potentiometer RV3	27284-764
19	Potentiometer RV4	27284-765

MEGGER spares should be ordered from the London Instrument Repair Centre at Dover. See page 4.

Recommended spares

Instrument Repairers are recommended to stock these spare parts for the repair of MEGGER BM7 testers.

<i>Item no.</i>	<i>Description</i>	<i>Part no.</i>
1	Test lead (red)	6320-058
	Test lead (black)	6320-059
2	Instruction card	6170-418
3	Fuse	25413-252
4	Cover assembly (complete)	6330-414
5	Window	5140-021
6	Case assembly (complete)	6330-412
7	Battery cover	5110-024
8	Terminal socket (black)	25267-207
9	Terminal socket (red)	25267-208
10	Battery clip (large)	5130-044
11	Battery clip (small)	5130-045
12	Movement (complete) BM7-500	6330-415
	Movement (complete) BM7-250	6330-416
13	Printed circuit board assembly (BM7-500)	6230-314
	Printed circuit board assembly (BM7-250)	6230-315
14	Transformer	A27888-770
15	Microswitch	25475-556
16	Potentiometer RV1	27284-762
17	Potentiometer RV2	27284-763
18	Potentiometer RV3	27284-764
19	Potentiometer RV4	27284-765

MEGGER spares should be ordered from the London Instrument Repair Centre at Dover. See page 4.

BM7-250

Components list

Circuit ref	Component
<i>Item</i>	
R1	680 Ω resistor \pm 2%
R2	510 Ω resistor \pm 2%
R3	51k Ω resistor \pm 2%
R4, R5	180 Ω resistor \pm 2%
R6	3.9k Ω resistor \pm 2%
R7	12M Ω resistor \pm 20%
R8	100 Ω resistor \pm 2%
R9	1k Ω resistor \pm 2%
R10	100k Ω resistor \pm 2%
R11	91 Ω resistor \pm 2%
R12	510 Ω resistor \pm 2%
R13	24k Ω resistor \pm 2%
R14	4.7 Ω resistor \pm 2%
R15	75k Ω resistor \pm 20%
TH1	470 Ω thermistor \pm 20%
RV1	220 Ω potentiometer \pm 20% 0.1W
RV2	1k Ω potentiometer \pm 20% 0.15W
RV3	470 Ω potentiometer \pm 20% 0.1W
RV4	10k Ω potentiometer \pm 20% 0.15W
VT1, VT2, VT3	transistor ACY21
C1, C2	10 μ F capacitor 25V
C3	0.01 μ F capacitor 500V \pm 20%
C4	10 μ F capacitor 25V
C5	0.01 μ F capacitor 500V \pm 20%
C6	1 μ F capacitor 63V + 50% - 10%
D1	diode BZY88C5V1
D2, D3	diode IN4148
D4, D5	diode BYX10
D6, D7	diode BYX10
D8	diode BZY88C5V1
	PC Board
	Switch bracket
	Transistor mounting pad
	Heatsink
	1 Fuse clip

BM7-250

Component Location

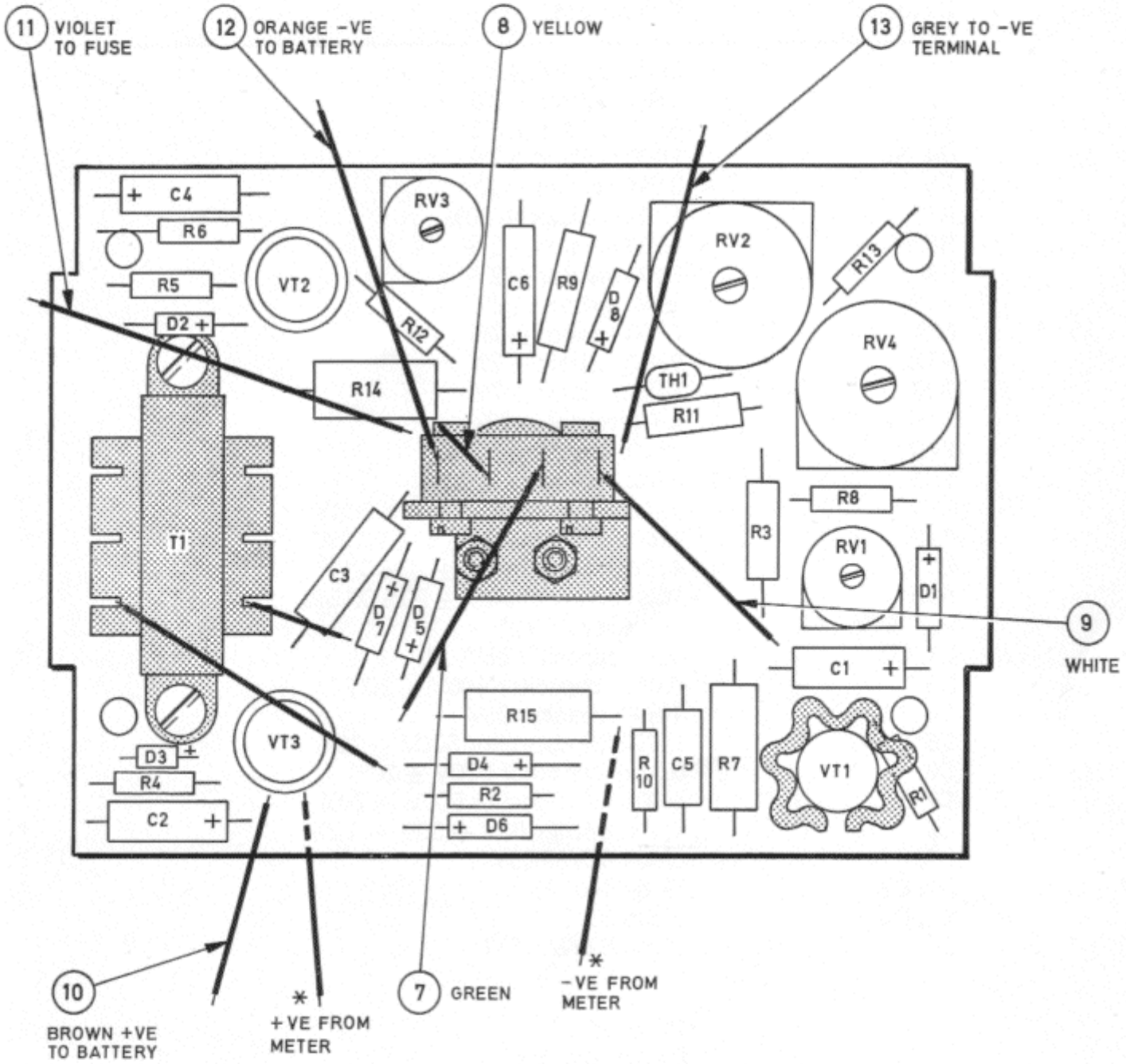
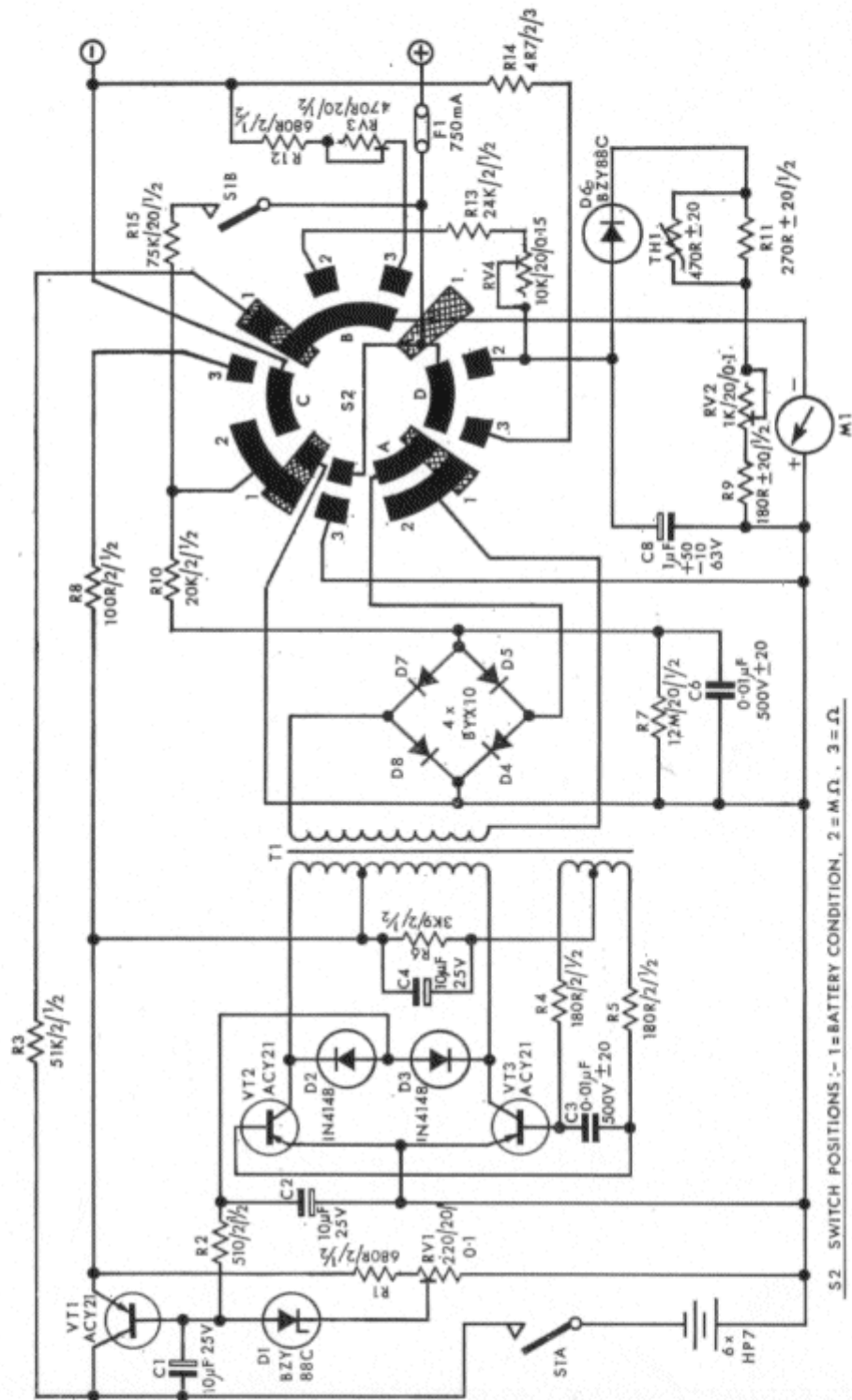

Fig. 7

BM7-250

Circuit Diagram



S2 SWITCH POSITIONS :- 1= BATTERY CONDITION, 2 = M.Ω., 3 = Ω.

Fig. 8

BM7-500

Components list

Circuit ref	Component
R1	680 Ω resistor \pm 2%
R2	510 Ω resistor \pm 2%
R3	51k Ω resistor \pm 2%
R4, R5	180 Ω resistor \pm 2%
R6	3.9k Ω resistor \pm 2%
R7	12M Ω resistor \pm 20%
R8	100 Ω resistor \pm 2%
R9	180 Ω resistor \pm 2%
R10	20k Ω resistor \pm 2%
R11	270 Ω resistor \pm 2%
R12	680 Ω resistor \pm 2%
R13	24k Ω resistor \pm 2%
R14	4.7 Ω resistor \pm 2%
R15	75k Ω resistor \pm 20%
TH1	470 Ω thermistor \pm 20%
RV1	220 Ω potentiometer \pm 20% 0.1W
RV2	1k Ω potentiometer \pm 20% 0.15W
RV3	470 Ω potentiometer \pm 20% 0.1W
RV4	10k Ω potentiometer \pm 20% 0.15W
VT1, VT2, VT3	transistor ACY21
C1, C2	10 μ F capacitor 25V
C3	0.01 μ F capacitor 500V \pm 20%
C4	10 μ F capacitor 25V
C5	0.0047 μ F capacitor 500V \pm 20%
C6	0.01 μ F capacitor 500V \pm 20%
C7	0.0047 μ F capacitor 500V \pm 20%
C8	1 μ F capacitor 63V + 50% - 10%
D1	diode BZY88C5V1
D2, D3	diode IN4148
D4, D5	diode BYX10
D6	diode BZY88C5V1

PC Board

Switch bracket

Transistor mounting pad

1 Fuse clip

BM7-500

Component Location

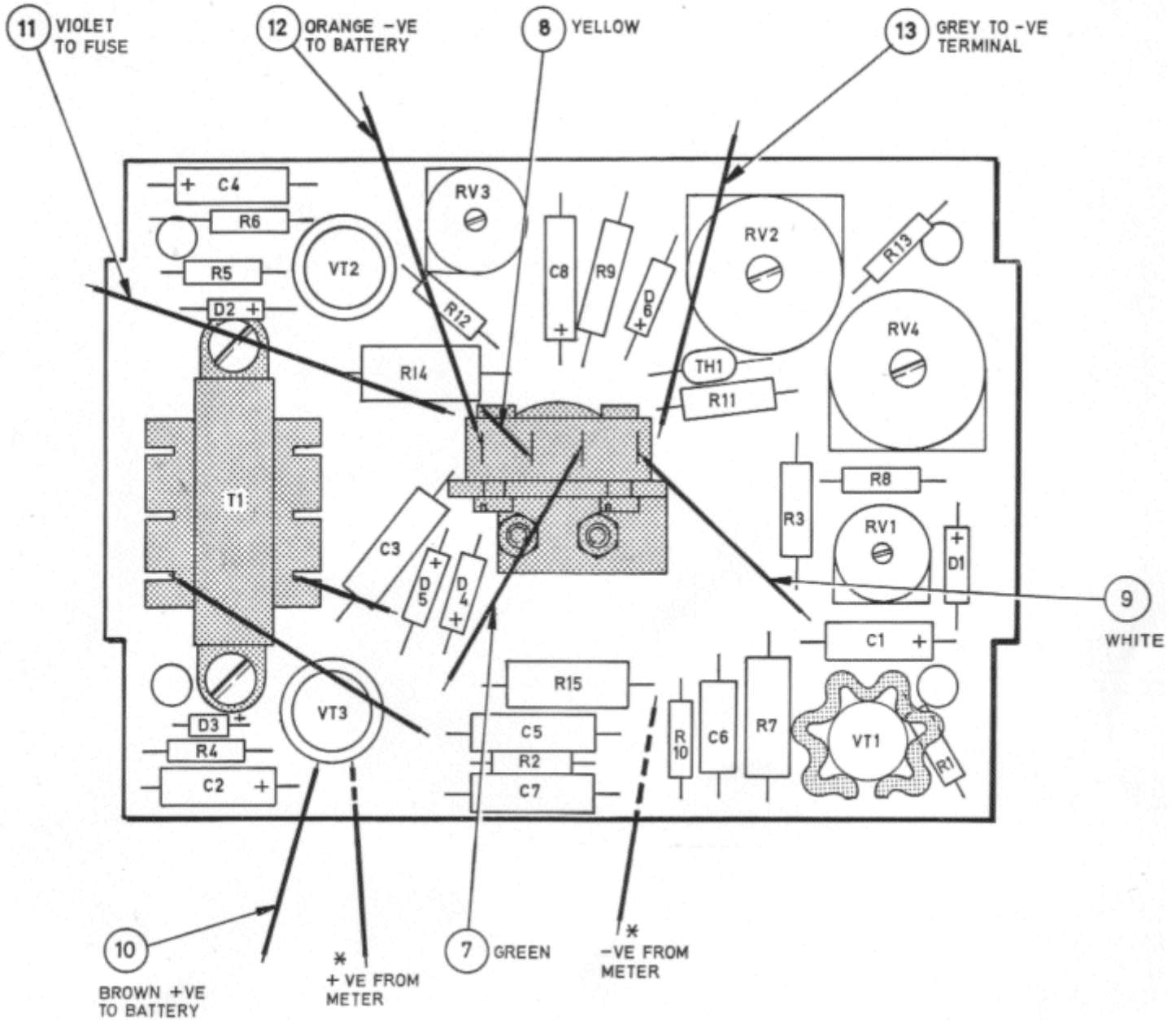
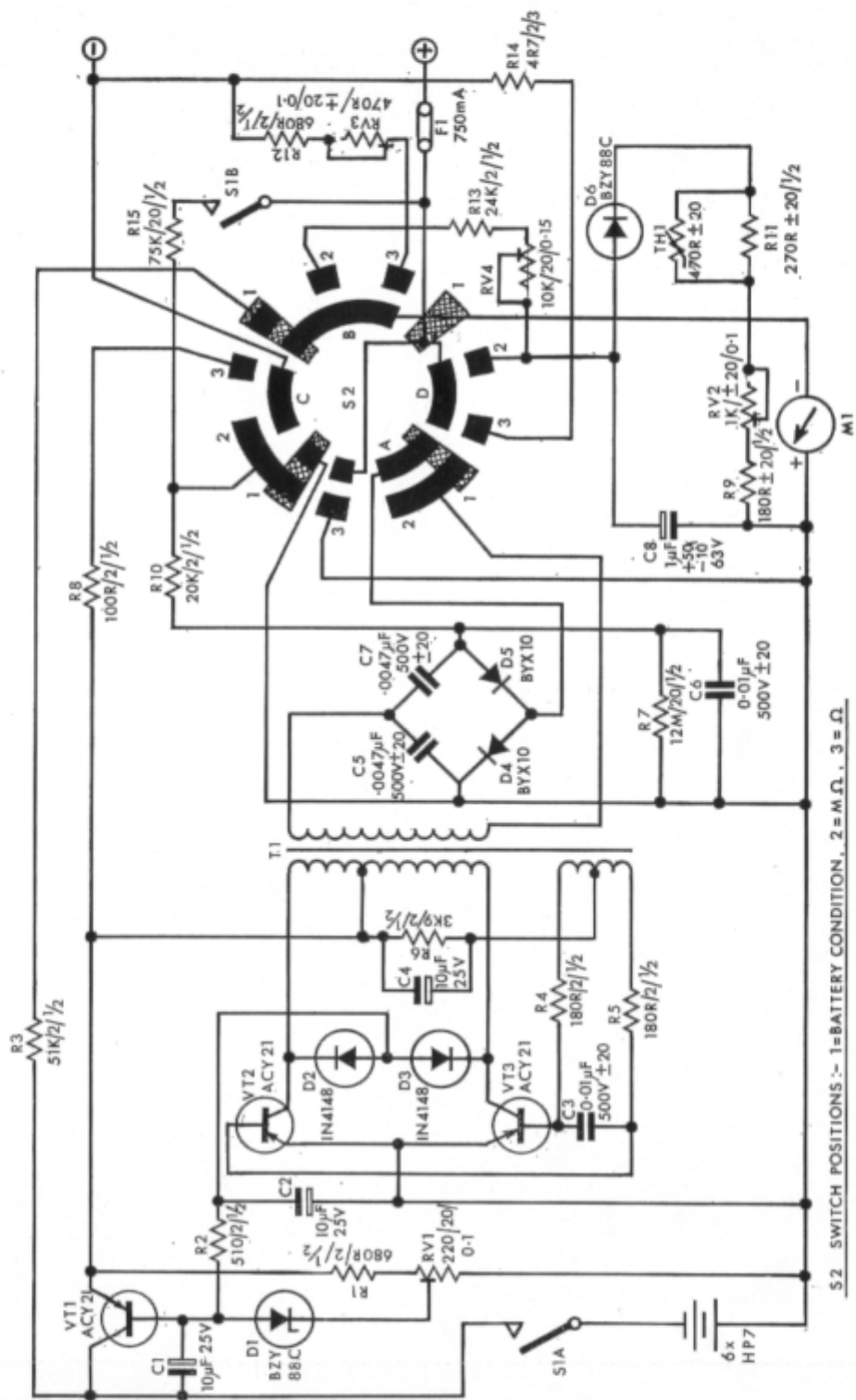

Fig. 9

BM7-500

Circuit Diagram



S2 SWITCH POSITIONS :- 1=BATTERY CONDITION, 2=M.Ω., 3=Ω.

Fig. 10